

C2-A4 Compression Latch

Lever latch - Access indicator

Features

- Visual access status
- Easy grip adjustment
- Push button actuation
- Integrated bumper screw
- NEMA 4 and IP65 enabled using supplied gasket

Material

- Zinc alloy, powder coated or chrome plated and steel, zinc plated

Product Performance

- Maximum static load: 200 N

Installation Notes

- For door thickness greater than 5, calculate screw length using the following formula:
Door thickness +12

Accessories

- Indicator reset key (C2-26-301-05)



Access Indicator

- Green – Unaccessed
- Red – Accessed (Operated)

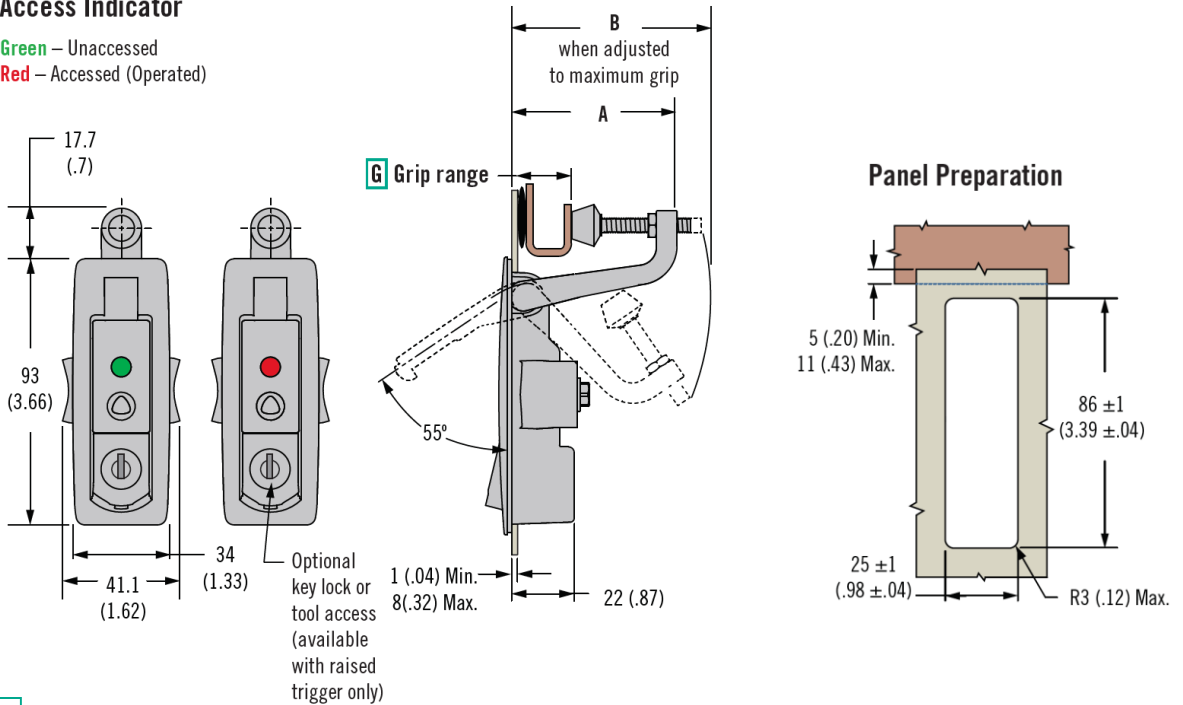

L Lock Styles



L Lock style

- 1 Non-locking raised trigger
- 2 Key-locking raised trigger keyed CH751 (two flat keys supplied)
- 3 Flush trigger non-locking
- 4 4 (.16) Hex recess raised trigger
- 10 No. 2 Phillips raised trigger
- 13 Locking without lock core (*contact Gripwell for lock core options*)
- 14 Railway standard
- 15 Hex recess raised trigger
- 16 Slotted recess raised trigger

F Finish

- 1 Textured chrome
- 5 Black powder coated

P Packaging option

- 3 Latches are sold layer packed
Omit for individually packaged latches.

C2 - A4 **G** - **L** **F** - **P**

G Grip Range	A	B
2	1 - 18 (.04 - .71)	35 (1.38) 65 (2.56)
3	17 - 39 (.67 - 1.53)	57 (2.24) 85 (3.35)